

Control

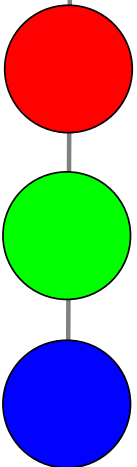

Product Overview

The TRYKA Smart Card Control System has been designed to compliment the TRYKA range of LED RGB fixtures and driver solutions.

The system offers simple plug and play installation without the need for complex on site commissioning and is ideal for small to medium sized colour change installations.

The control sequence includes the most popular functions such as variable speed fading, strobe and fixed colours.

Application specific functions can be supplied pre-programmed on the SMART CARD.

Features

- Easy to operate
- Wide range of operating modes
- Compact low profile design
- Stand alone or Wall plate operation
- Simple Plug and Play Installation
- Easy program upgrade
- Power loss memory
- Silent Operation
- Energy Efficient
- Can be configured for other DMX equipment

Specifications – Control Unit

Electrical Specifications

Input

Input Voltage Range	230V AC 50Hz
Power Consumption	3.6 W
Power Factor	0.95
Connector	Wieland GST18
Ambient Temp	50°C MAX

Output

Data Output	DMX 512
Red	Address 1
Green	Address 2
Blue	Address 3
Connector	RJ45
Fixed scenes	16 set by smart card
Min Fade time	2 Seconds
Max Fade time	1 Minute

- 1:Maximum Modulation Driver Load 30units
2:Additional Units will require amplifier

Mechanical Specifications

Dimensions	150 x 35 x 180 mm
------------	-------------------

Specifications – Remote key pad

Electrical Specifications

Recommended Cable	Category 5 UTP
Connection	Screw Terminals
Maximum distance between SMART CARD CONTROLLER and key pad is 10 meters	

Mechanical Specifications

Dimensions	86 x 86 mm
Fixes to Standard	Single BS4662 type Flush mounted box 25mm minimum depth

Control

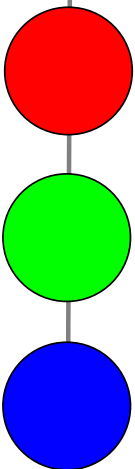

Typical Installation

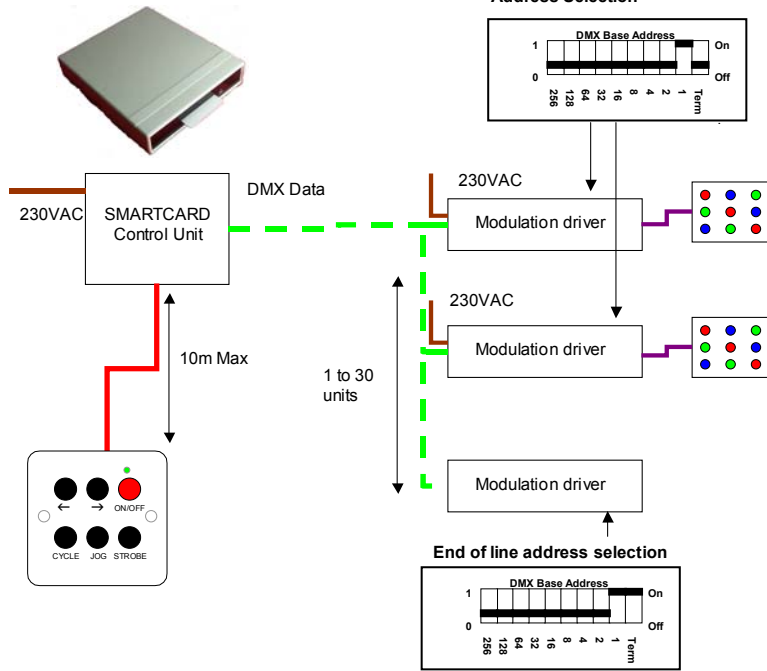

Control

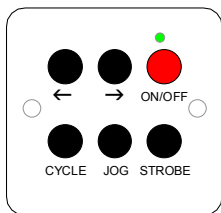
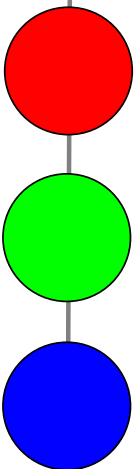

Key pad functions

- ON / OFF** Sends DMX zero to all fixtures, light output 0%. will switch optional power relay for mains isolation
- CYCLE** Starts fade through of the 16 scenes specified on the smart card. Press again to hold sequence at a desired colour
- JOG** Selects one of sixteen fixed colours
- STROBE** Starts Strobe mode, switches through fixed scenes defined on smart card
 - Speeds up CYCLE and STROBE sequence, selects scenes in JOG mode
 - ← Slows down CYCLE and STROBE sequence, selects scenes in JOG mode

SMART CARD PROGRAM

The Colour Change controller is supplied with the following fixed scenes. A total of 16 can be specified for custom programmed cards. For details of Custom programs please contact TRYKA

Standard Scenes

- 1 Red
- 2 Blue
- 3 Green
- 4 Cyan
- 5 White (warm)
- 6 White (cool)
- 7 Magenta
- 8 Amber

Selection Guide

Part No

TS-MT

Smart Card controller complete with remote wall plate and standard program card. Ask for details if a custom cross fade or program is required.

Control

