

Installation by PSD
Electronics, pictures
courtesy of Wine Inns

About M-Club

This innovative design maximises the full potential of the Tryka RGB linear system to it's full potential.

Each window uses 2 wide angle linear extrusions to give bright saturated colours. Every window has a unique DMX address – enabling a myriad of control and scene options.

The total power consumption is around 1800 watts – with a lamp life exceeding 50,000 hours !

Get more ideas online at www.tryka.co.uk

In the daytime...



And at night...



Window Feature Construction

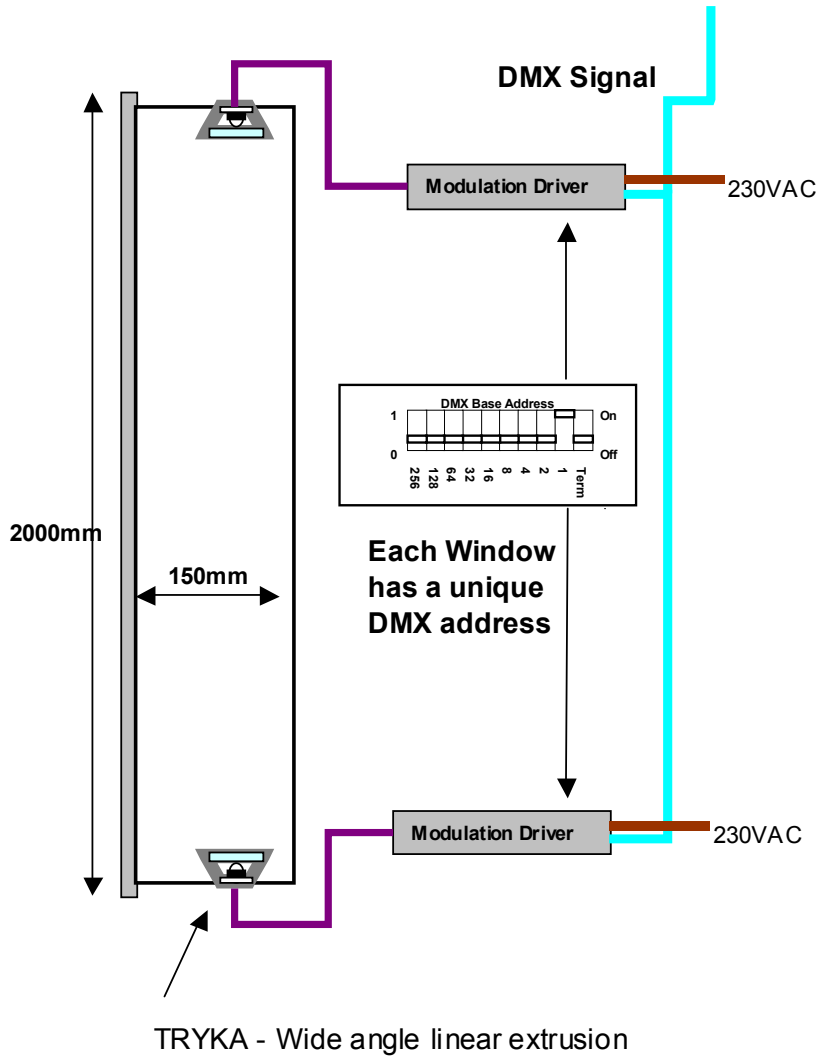

Tryka Ideas

