

HP12-WMTR

12 CHANNEL 2.4 kVA DIGITALLY CONTROLLED WALL MOUNTING DIMMER RACK



DESCRIPTION

The Jands HP12-WMTR is a wall mounting high quality, rugged, 12 channel 2.4 kVA per channel dimmer rack specifically designed for demanding contracting / theatre applications.

A separate wall bracket simplifies the installation process. It allows cabling to be routed to the dimmer location prior to the installation of the actual dimmer units, providing the contractor with the ability to fit off the dimmers when the site is secure.

As an option a 24 way patch panel kit is available which, when combined with the extended wall mounting bracket, provides the end user with an economical and compact combined dimmer rack-patch system.

FEATURES

- * Microprocessor control
- * Built-in captive nuts for rigged applications
- * Single or three phase operation
- * Easy to use menu driven software
- * 14.3 bit firing resolution for optimum power control
- * Function keypad with LED indicators/"LOAD" & "DRIVE" LED per channel
- * "DMX RECEIVED" LED & "1/2/3 PHASE" LED (indicates 3-phase supply OK)
- * Scrolling 4-digit 16-segment alpha-numeric display
- * "SELECT" switch per channel (controls function)
- * "STATUS" LED per channel (indicates modified output, i.e. 120V)
- * Fan assisted convection cooling
- * Rotary encoder for function/level select
- * DMX start address code selected by banks or specific start channel
- * Neutral failure and over-voltage detect with override facility
- * Automatic mains input fluctuation compensation (+15%)
- * Over-temperature detect/warning
- * User lock facility
- * Dimmer "wakes-up" in previously selected mode
- * Built-in test facilities
- * Front panel software upgrade capability
- * Stand alone operation with individual channel level control
- * Pre-heat facility on a per channel basis
- * Selectable output voltage (240V/120V/60V chopped) on a per channel basis
- * Six built-in factory programmed chase functions
- * Switched output selectable on a per channel basis
- * Dimmer will hold last DMX value should control data be interrupted
- * Ability to store up to three DMX snapshots
- * Ability to build two (non-volatile) custom scenes which can be stored and recalled later
- * Toroidal chokes
- *

OVERALL SPECIFICATIONS

Channels:	12
Power rating:	2.4 kVA per channel
Power supply type:	3-phase, 240V phase-to-neutral (415V phase-to-phase) with earth (single phase version available)
Power requirements:	Nominally 240V/50 Hz (limits 47Hz - 54Hz) Under-voltage symptoms appear if all phase voltages fall below 190V Internal electronics will tolerate 415V on all phases
Supply protection:	50 amps per phase (max.)
Dissipation:	<1.0% of output load (288W max.)
Dimmer curve:	Linear power/switched
Max. ambient operating temp:	40°C maximum for 100% duty cycle. Warning message displayed at 65°C heatsink temperature.

Control input:	USITT DMX-512/1990 protocol
Input connector:	Internal terminal strip
Mains injected tone limits:	15Vrms @ 750Hz, 25Vrms @ 1050Hz
Output connectors:	1 × 3-pin 10 Amp outlet (JND-HP12TR-A) per channel (see ordering information below)
Output risetime:	280 microseconds with 2400W incandescent load. Output current risetime 50mA/μs
Output protection:	Magnetic circuit breakers (0.1-1 sec. delay @ 200% overload, instantaneous @ 700% overload)
Test facility:	Individual channel selection using channel select switches and software menu
Dimensions:	482mm(W)×158mm(D)×485mm(H) (with wall mounting bracket)
Net/shipping weight:	23kg

SUPPLIED ACCESSORIES

- 1 × wall/rack mounting bracket
- 1 × operating manual

ORDERING INFORMATION

MODEL/PART	PART NO.
• HP12-WMTR with 12 × 10 Amp Australian outlets	JND-HP12WMTR-A
• HP12-WMTR with 12 × hard wired outputs	JND-HP12WMTR-H
• Extended wall mounting bracket	JND-WM-EBP
• Patch kit (Refer to the Technical Specification Sheet of WM-Patch)	
• 40 amp flexible lead & DMX socket kit <i>(Factory fitted at time of ordering)</i>	JND-WM-FLEX

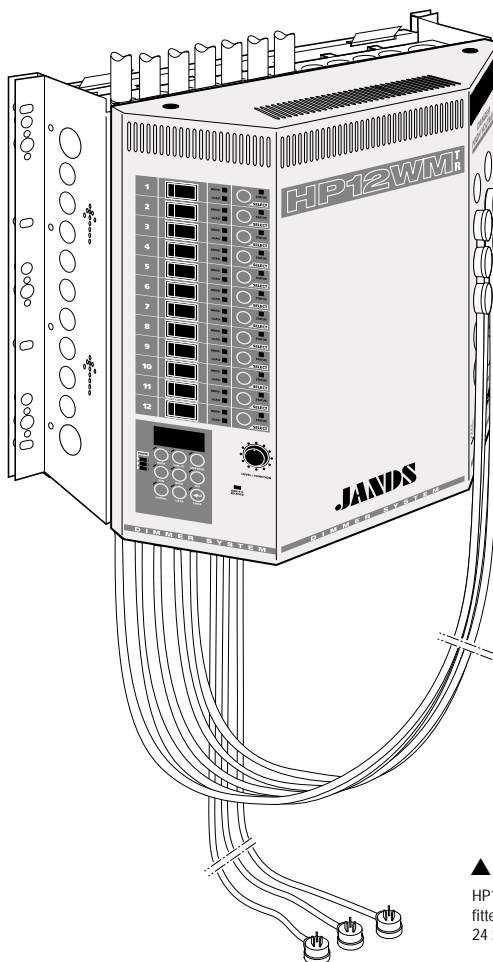

▲ HP12-WMTR dimmer fitted with optional 24 x Patch system

12 CHANNEL 2.4 kVA DIGITALLY CONTROLLED WALL MOUNTING DIMMER RACK

HP12-WMTR

HP12-WMTR

12 CHANNEL 2.4 kVA DIGITALLY CONTROLLED WALL MOUNTING DIMMER RACK



ARCHITECTS & ENGINEERS SPECIFICATION

Electronics

The dimmer shall receive and decode banks of twelve (12) control signals complying with the industry standard USITT DMX-512/1990 protocol. The DMX start channel shall be adjustable to any DMX channel, or in banks of twelve (12). If the DMX signal is interrupted, the dimmer outputs shall default to the last received DMX frame.

The dimmer shall have a control response time of not more than twenty (20) milliseconds, input to output.

The dimmer shall utilise a highly visible four (4) character alpha-numeric LED display to provide parameter and editing information to the operator. The dimmer shall also utilise red and green LEDs to show channel status and output level information to the operator.

The dimmer shall have a memory capacity of at least 512Kbytes and shall be battery-backed to prevent memory loss when switched off. The battery shall have a life of at least four (4) years.

For heatsink temperatures above 50°C (122°F) the temperature controlled fan shall run at full speed. The dimmer shall feature temperature monitoring electronics that will display a warning message when the internal heatsink temperature exceeds 65°C (149°F), and will trigger a thermal shut-down mode when the heatsink temperature exceeds 85°C (185°F). A hard-wired thermal switch shall disable the dimmer should the heatsink temperature exceed 100°C.

The dimmer shall utilise Toroidal inductors which are acoustically quiet and provide a risetime in excess of 280 microseconds. Dimmers using conventional gapped iron core chokes will not be acceptable.

The dimmer shall utilise a digitally-generated dimmer curve to accurately match a linear control voltage versus power output relationship. The dimmer shall also feature a switching curve for on/off applications. Each of the twelve (12) dimmer channels shall smoothly control loads from 25 watts to 2400 watts.

The dimmer shall detect and inform the operator of substantial mains supply imbalances, over-voltages and a bad (soft) neutral connection without blowing fuses or sustaining damage. The dimmer shall compensate (when possible) for mains supply fluctuations of up to ±15%.

The dimmer operating software shall incorporate diagnostic test routines that exercise the different systems on the CPU card. These test routines shall indicate to the operator (using LEDs and/or displays) the result (pass/fail) of the tests.

The dimmer shall display an error message to the operator should the software malfunction or be corrupted. The dimmer shall indicate the current operating mode by means of the alpha-numeric display or individual LEDs on the keypad.

The dimmer shall be capable of selecting an alternative output voltage (e.g. 120 volts) for designated channels. The dimmer shall provide the means to test outputs by allowing the operator to manually fade individual channels from zero to full. The dimmer shall provide the means to disable individual channel outputs. The dimmer shall provide a selectable lamp filament preheat voltage to reduce mains inrush to lamps.

The dimmer shall be factory tested and cyclically burned-in for a minimum of 24 hours.

Electrical

The dimmer shall operate from a three-phase plus neutral and earth supply of 415 volts AC phase-to-phase with a nominal supply frequency of 50Hz. The dimmer shall draw 40A per phase when all output channels are fully loaded. All channel outputs shall be protected by fast-acting magnetic circuit breakers.

Mechanical

The dimmer fitted with supplied wall mounting bracket shall be 482mm wide x 158mm deep x 485mm high. The dimmer shall be constructed of 1.2 mm steel, and shall be provided with a removable front cover for access to internal electronics. All metal surfaces shall be properly treated and finished in powdercoat or zinc passivating.

A separate wall mounting bracket shall allow the contractor to install the cabling to the proposed dimmer

location, prior to the actual on site installation of the dimmer unit itself. An optional extended mounting bracket will facilitate the installation of the dimmer in applications.

An optional patch system (24 way) which integrates into the optional extended wall bracket system shall be available.

The control surface shall be scratch-resistant 0.25 mm Lexan with legends reverse silk-screen printed from behind.

Adequate ventilation must be provided.

The dimmer shall be the JANDS HP12-WMTR.

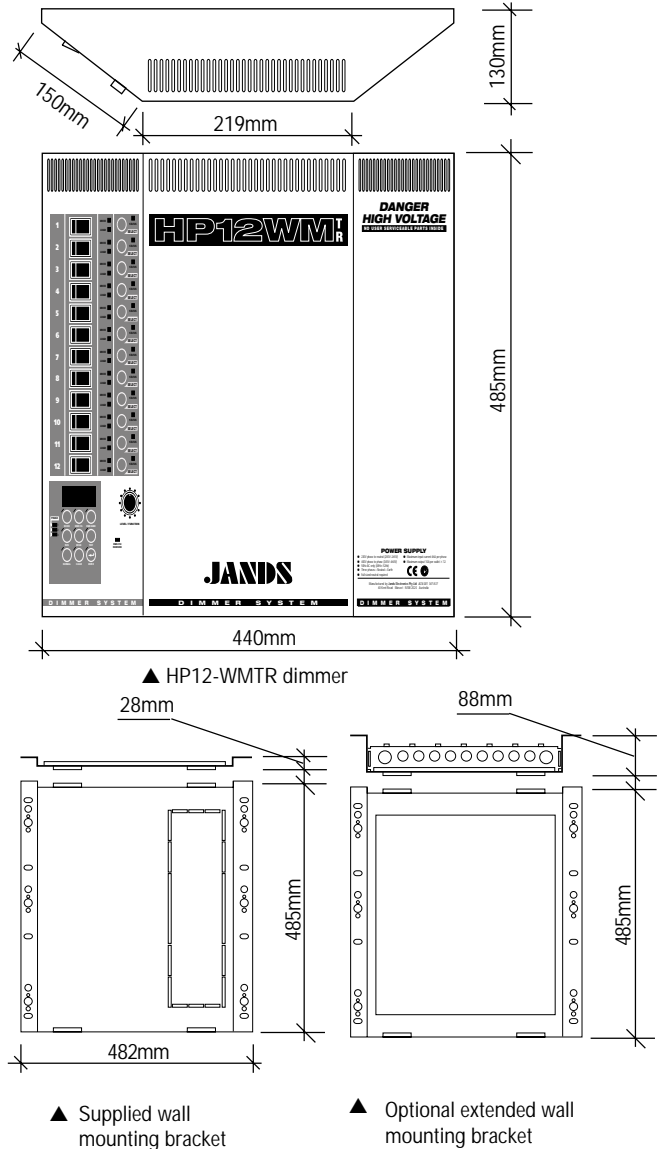

12 CHANNEL 2.4 kVA DIGITALLY CONTROLLED WALL MOUNTING DIMMER RACK

1 THROUGH WALL CABLE ENTRY

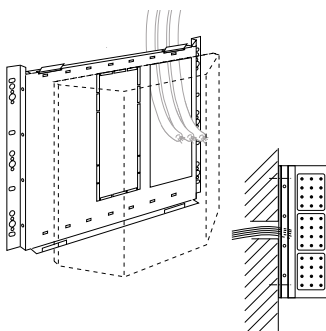

2 SURFACE MOUNTED CONDUIT

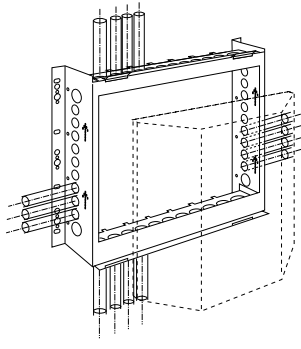

3 CABLE TRAY

(shown with top/bottom conduit plates removed)

